

FRONT ELEVATION

SIDE ELEVATION

REAR ELEVATION

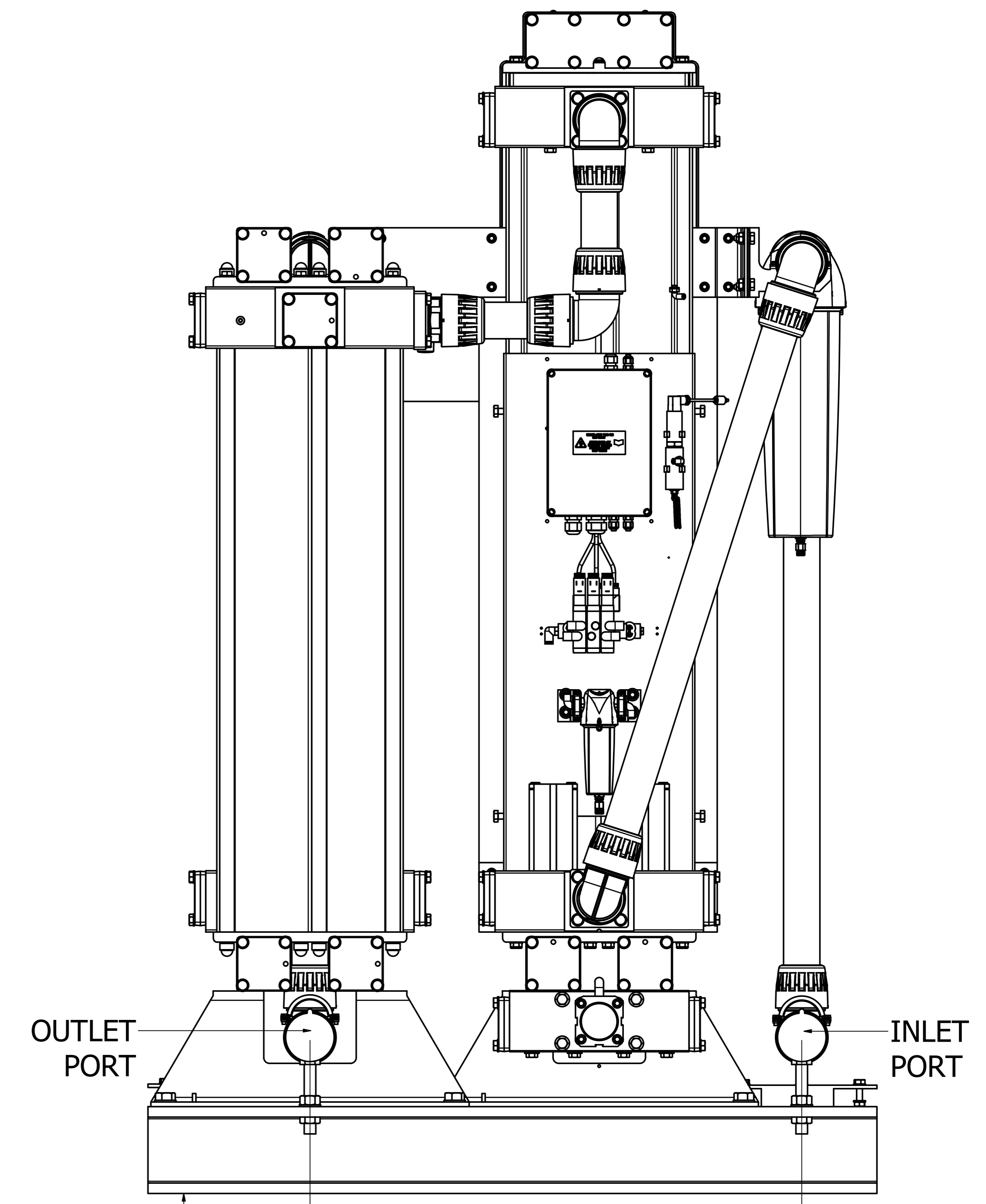
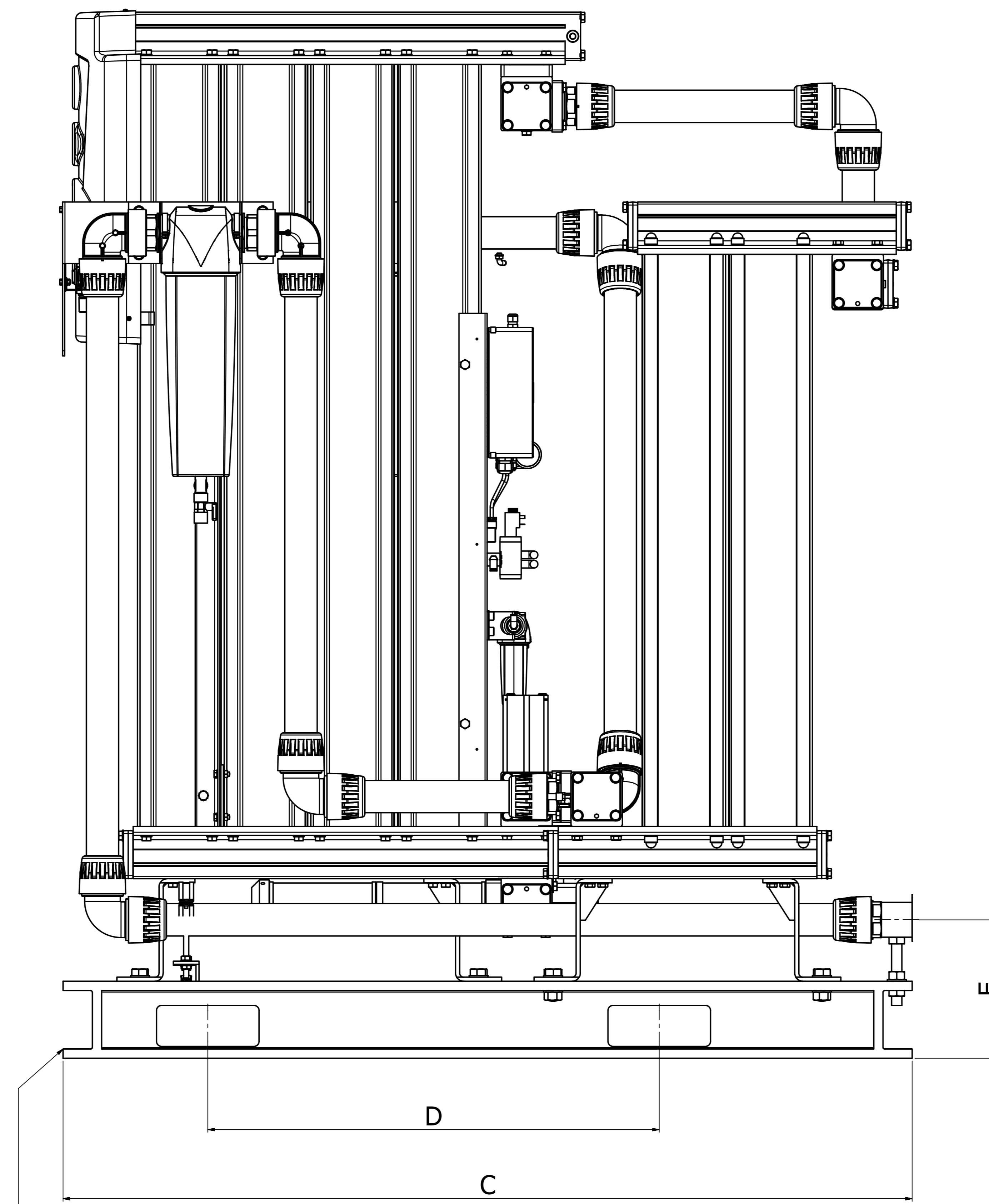
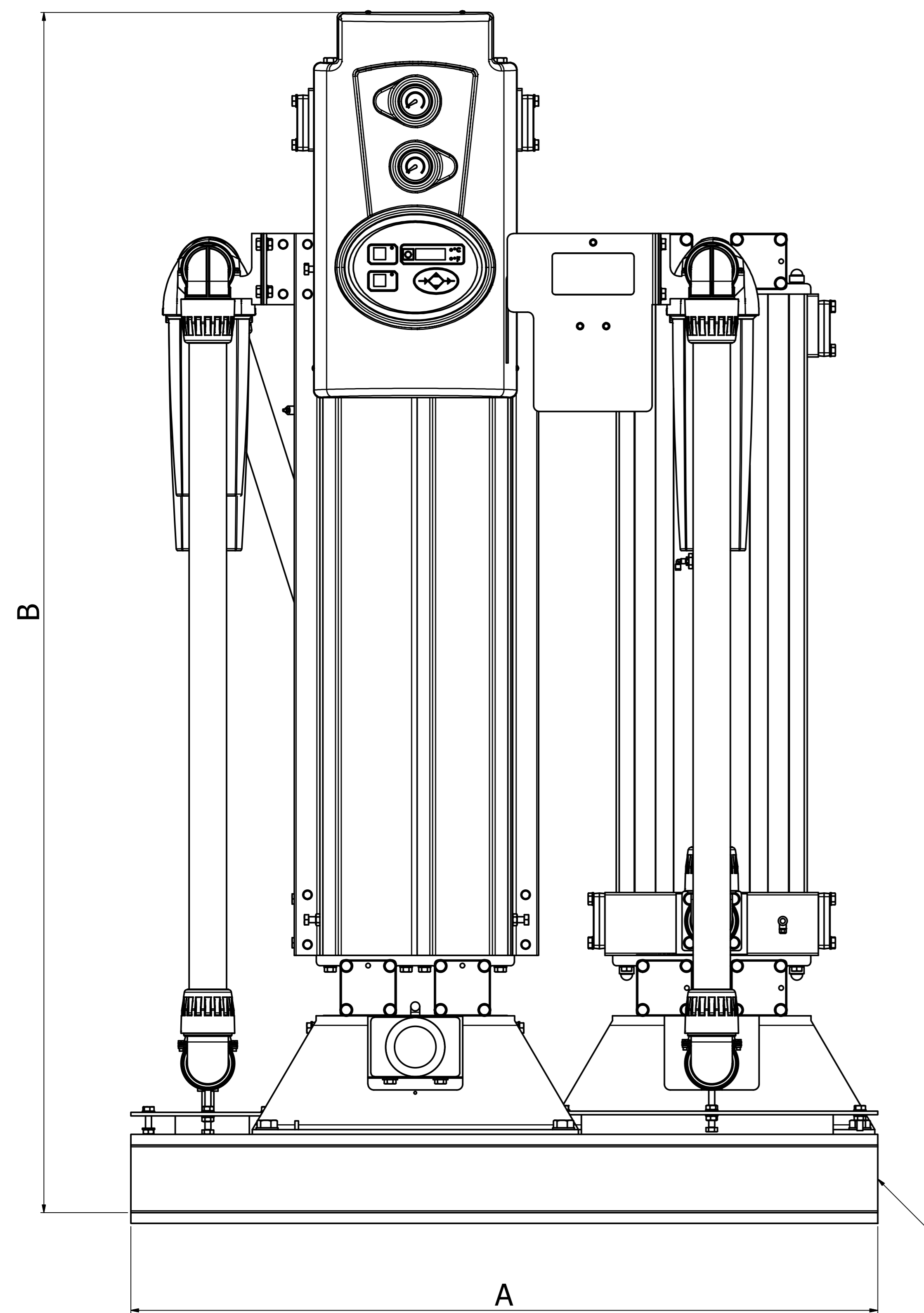

← C OF G PLANE 'Y'

→ C OF G PLANE 'X'

↑ C OF G PLANE 'Z'

BAM REFERENCE	DIM 'A' (M)	DIM 'B' (M)	DIM 'C' (M)	DIM 'D' (M)	DIM 'E' (M)	DIM 'F' (M)	INLET PORT	OUTLET PORT	MASS (KG) APPROX	C OF G 'X' (M)	C OF G 'Y' (M)	C OF G 'Z' (M)
BAM70	1.26	2.042	1.950	0.880	0.270	0.850	2 1/2" BSPP	2 1/2" BSPP	1400	0.931	0.661	0.925
BAM50	1.26	2.042	1.950	0.880	0.270	0.850	2 1/2" BSPP	2 1/2" BSPP	1100	0.860	0.615	0.878
BAM40	1.26	2.042	1.655	0.880	0.270	0.850	2" BSPP	2" BSPP	900	0.722	0.619	0.859
BAM30	1.26	2.042	1.655	0.880	0.270	0.850	2" BSPP	2" BSPP	800	0.702	0.598	0.828
BAM20	1.26	1.797	1.655	0.880	0.270	0.850	2" BSPP	2" BSPP	700	0.663	0.622	0.745
BAM10	1.26	1.797	1.655	0.880	0.270	0.850	2" BSPP	2" BSPP	600	0.655	0.599	0.691

ECD No. 0042454 REV -

PLEASE CONSIDER THE ENVIRONMENT PRIOR TO PRINTING THIS DRAWING

DO NOT SCALE - IF IN DOUBT ASK

BASED ON BS 8888 DIMENSIONS IN MILLIMETRES

GENERAL TOLERANCES UNLESS OTHERWISE STATED

MACHINED DIMENSIONS
 XX 40-15 UP TO 300 ±0.3
 X 40-15 OVER 300 TO 500 ±0.5

POSITIONAL TOLERANCE
 PLAIN HOLES 00.13
 TAPPED HOLES 00.25
 CONDUCTIVITY TOLERANCE 0.13 TR

MACHINED SURFACES INDICATED THIS SURFACE TEXTURE IS TO BS 5134 VALUES IN MICROMETRES

ANGLES ±10° (EXCEPT CHAMFERS)

FINISHES
 METRIC THREADS TO BS 3642 PFD CLASS
 EXTERNAL, 60 INTERNAL, 60
 PTFE THREADS
 PRESSURE TIGHT TO BS 21

SHEET METALWORK & FABRICATORS
 SHEET METALWORK DIMENSIONS
 UP TO 500 ±0.5
 OVER 500 TO 1000 ±1.0
 OVER 1000 ±1.5

FABRICATED PARTS DIMENSIONS
 UP TO 500 ±0.5
 OVER 500 TO 1000 ±1.0
 OVER 1000 ±1.5

POSITIONAL TOLERANCE FOR PLAIN & TAPPED HOLES
 UP TO 500 01.0
 OVER 500 02.0

Parker domnick hunter
 Parker Hannifin Manufacturing Ltd
 domnick hunter Filtration & Separation Division
 Dalkey, East Valley
 Glasgow, G11 0PQ
 TEL: +44 (0)191 402 5000
 FAX: +44 (0)191 402 5096
 www.parker.com/dhfrs

THIS DOCUMENT IS COPYRIGHT AND IS THE PROPERTY OF PARKER HANIFIN LTD. IT MUST NOT BE COPIED OR REPRODUCED IN ANY MANNER WITHOUT THE WRITTEN PERMISSION OF PARKER HANIFIN LTD. © 2011 A0

DRG No. 101-10270 SHEET 1/1

MATERIAL GEN. ARTT.	SCALE 19:100	DRAWN d187385	CHECKED SS	APPROVED SB	TITLE BAM CO/CO2 REDUCTION SKID RANGE
		DATE 03/06/2013	DATE 28/08/2013		